



Budenberg



Made in Britain

Unit B2, Stuart Road,
Altrincham Business Park,
Altrincham WA14 5GJ,
United Kingdom.

budenberg.co.uk
sales@budenberg.co.uk
+44 (0)161 777 7300

Model: 511-4-AL-2

For power cables. The model 511-4-AL-2 Watertight HV cable Gauge has to continually operate in the remote severe environments where robustness coupled with repeatability are paramount.

The model 511-4-AL-2 is designed to meet many International and regulatory standards including ESI 50-1 that requires the gauges to be fully immersible under water and are Type Tested to industry standard NGTS 3.5.9 Issue 2*.

Units are supplied fitted with two electrically separate electrical contacts whose operation can be independently defined and adjusted by use of a removable key. Electrical connections are taken via a 5-wire three metre PVC insulated and sheathed cable from the side of the case, the wires are colour coded for ease of installation.

* Certification available upon request

Sizes

100 mm (4")

Mounting

Direct / Surface

Case & Bezel

Machined solid aluminium, grey polyester powder coated, with back flange

Scale Ranges

-1 to 1 Bar up to -1 to 25 Bar

Dual Scale units or custom scales can be provided

Pressure Element

316 stainless steel body and tube

Overload

Units will withstand overload pressure up to 130% FSD.

Pressure Connection

3/8" BSP Pipe Fitting

Other connections available, please contact our Sales Office

Electrical Contacts

Also available with independent single, double or triple contacts (see reverse of datasheet for more details)

Accuracy Class

1% of FSD as defined in EN837-1 NGTS

3.5.9 Issue 2* Type Tested.

Temperature

Operating: -20 to +90 Degrees C

Storage: -40 up to + 100 Degrees C

Temperature Effect

Variation in indication caused by temperature shall not exceed $\pm 0.04 \times (t_2 - t_1)\%$ of the span where:

t_1 is the reference ambient temperature in degrees Celsius

t_2 is the ambient temperature in degrees Celsius

WATERTIGHT PRESSURE GAUGE FOR HIGH VOLTAGE CABLES WITH DOUBLE ELECTRICAL CONTACTS



Dial

White anodised Aluminium with black scales and anti-parallax mirror
Option: Dual scales or special dial markings are available

Pointer

Black painted stainless steel

Movement

Stainless Steel

Window

Acrylic Plastic Window

Environmental Rating IP68 as defined in EN 60 529

Traceability

All instruments are individually calibrated and have a unique Serial Number printed on the dial. A Certificate of conformity traceable to National Standards is supplied free of charge.

Certification available

BS EN 10204 3.1B Material Certification Point by point Certificate

Safety

All units are manufactured to comply with EN 837-1 and other regulatory standards including P.E.D.

Installation Instructions

Refer to EN 837-2

Dimensions

Model : 511-4-AL-2

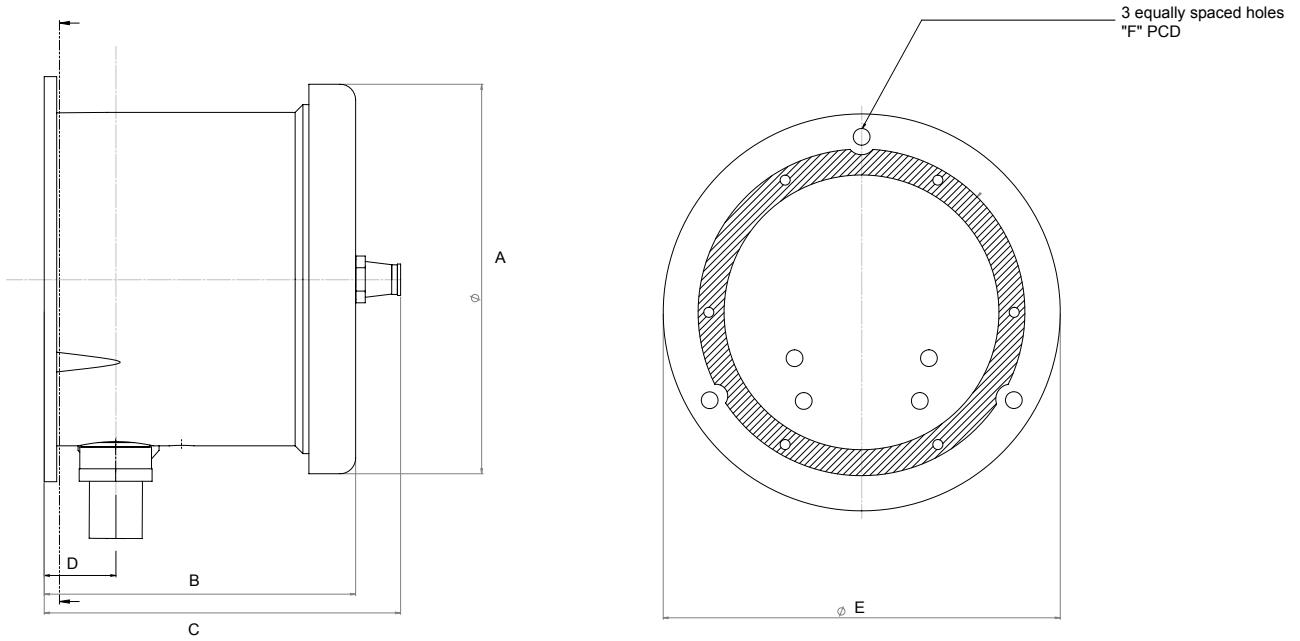

Model No:	A	B	C	D	E	F
511-4-AL-2	125mm	97mm	112mm	23mm	128mm	115mm

Electrical Contacts

Units are supplied with two independently settable Model 144 electric contacts, each of which can have a different mode of operation as follows :-

- Make on Rising Pressure **MR** - contacts normally open but close when rising pressure achieves the pressure setting.
- Break on Rising Pressure **BR** - contacts normally closed but open when rising pressure achieves the pressure setting.
- Make on Falling Pressure **MF** - contacts normally open but close when falling pressure achieves the pressure setting.
- Break on Falling Pressure **BF** - contacts normally closed but open when falling pressure achieves the pressure setting.

Standard Variants

The following are standard variants readily available based on configurations supplied to many of the world's large cable manufacturers

Model No 511-4-AL-2 Gauge fitted with 144 MF/MF, Double Make on Fall magnetically assisted electric contacts Spec R/3152, of PVC insulated and sheathed cable from side of case. 3/8" BSP pipe connection, range as specified by customer.

Accessories

Valves and Adaptors

A full range of Needle and Ball Valves to fit the Watertight Cable Gauges - See separate Datasheets.

Specifications and dimensions in this leaflet, are subject to change without prior notice.



<p>Budenberg Gauge Co. Ltd. Unit B2 Stuart Road Altrincham Business Park, Altrincham WA14 5GJ</p> <p>Tel: +44 161 777 7300. Email: sales@budenberg.co.uk</p>	<p>Budenberg Gauge Pvt. Ltd. 299-300, IInd Main Road, Nehru Nagar, Old Mahabalipuram Road (OMR), Chennai - 600 096, Tamil Nadu , India</p> <p>Tel : +91 44 24541074 Tel/Fax: +91 44 24541075 Email: sales@budenberg-gauge.in</p>	<p>Budenberg Gauge Asia Pacific Ltd</p> <p>Unit 109 Cheung Fat Ind Bldg 64-76 Larch St Tai Kok Tsui Kln Hong Kong</p> <p>Tel : +852 3709 0020 Email: sales@budenberg-gauge.asia</p>	<p>Budenberg Middle East LLC</p> <p>PO Box 18980 Dubai United Arab Emirates</p> <p>Tel: +971 4 2511670 Email: sales@bme-me.com</p>
--	--	---	--